



ARHT-E, ARHT
 Rod End Bearings - Self-Lubricating
 3 Piece, Heavy Duty, Male & Female

Plating: When specified in materials block, body Cadmium plated all surfaces per QQ-P-416, Type I, Class 2.

Dimensions: Dimensions apply after plating.

Option: 1. For left hand threads add "L" to prefix. Examples: ARHTL4E or ARHTL4.
 2. For keyway or keyslot options, add suffix "W" to part number.
 3. For "J" from threads per MIL-S-8879, add suffix "J" to part number. Examples: ARHT10EJW or ARHT10JW.
 4. To specify CRES 17-4PH race material, add suffix "H" to designation. Examples: ARHT8ECRH or ARHT8CRH.

Notes: UNF-3A = Male, UNF-3B = Female

MATERIALS

Part No.	Ball	Race	Liner	Body
Basic No.	CRES 440C, RC 55-62	CRES 410 Heat Treated	*Teflon/Fabric Permanently Bonded to race I.D.	C.M. STL, Heat Treated Cad. Plated
No. + CR	CRES 440C RC 55-62	CRES 410 Heat Treated	*Teflon/Fabric Permanently Bonded to race I.D.	CRES 17-4PH, Heat Treated

NMB Part Number	(B) Bore Diameter		(D) Head Diameter		(W) Ball Width		(H) Body Width		(O) Ball Diameter		(O) Shoulder Diameter		(F) Ball C/L to End		(E) Thread Size	(Q) Misalign-ment
	Inch	mm	Inch	mm	Inch	mm	Inch	mm	Inch	mm	Inch	mm	Inch	mm		
	+0.000	+0.000	+0.010	+0.25	+0.000	+0.00	+0.005	+0.13					+0.010	+0.25	UNF-3A	
	-0.0005	-0.013	.010	-0.25	-0.002	-0.05	-0.005	-0.13	Ref.	Ref.	Ref.	Ref.	-0.010	-0.25	UNF-3B	Ref.
ARHT4E ARHT4	.2500	6.350	.806	20.47	.375	9.52	.337	8.56	.531	13.49	.375	9.52	1.562	39.67	5/16-24	5°
ARHT5E ARHT5	.3125	7.938	.900	22.86	.437	11.10	.327	8.31	.593	15.06	.401	10.18	1.875	47.62	3/8-24	14°
ARHT6E ARHT6	.3750	9.525	1.025	26.04	.500	12.70	.416	10.57	.687	17.45	.471	11.96	1.938	49.22	7/16-20	9°
ARHT7E ARHT7	.4375	11.112	1.150	29.21	.562	14.27	.452	11.48	.781	19.84	.542	13.77	2.125	53.98	1/2-20	10°
ARHT8E ARHT8	.5000	12.700	1.337	33.96	.625	15.88	.515	13.08	.875	22.22	.612	15.54	2.438	61.92	5/8-18	9°
ARHT10E ARHT10	.6250	15.875	1.525	38.74	.750	19.05	.577	14.66	1.062	26.97	.752	19.10	2.625	66.68	3/4-16	12°
ARHT12E ARHT12	.7500	19.050	1.775	45.08	.875	22.22	.640	16.26	1.250	31.75	.892	22.66	2.875	73.02	7/8-14	13°

* A trade name of E.I. duPont de Nemours & Co., Inc.

See next sheet for further information

The information contained in this data sheet represents typical performance of the product, and is subject to change without notice. Product performance may be varied or enhanced to meet individual requirements. For further information please contact your local sales office



Rose Bearings Ltd., Lincoln Pl. Doddington Road, Lincoln, Lincolnshire LN63RA, England Tel: (44) 1522500933 Fax: (44) 1522500976
 NMB Minebea GmbH, Siemensstrasse 30, 63225 Langen Germany Tel: (49)6103-913-0 Fax: (49)6103-913-220
 NMB Minebea Srl, 5 Av. Des Bosquets, 9550 Baillieten France, France Tel: (33)1-34083939 Fax: (33)1-34083930
 NMB Italy Srl, Via A Grandi 39/41, 20017 Mazzo di Rho, Milan Italy Tel: (39) 2-939711 Fax: (39)2-93901154
 NMB Technologies Inc., 9730 Independence Avenue, Chatsworth, California USA Tel: (818) 341 3355 Fax: (818) 3418207
 Minebea Technologies Pte. Ltd. PSA Building, 460 Alexandra Road, #34-02, Singapore 119963 Tel: (65)278 8522 Fax: (65) 4446527

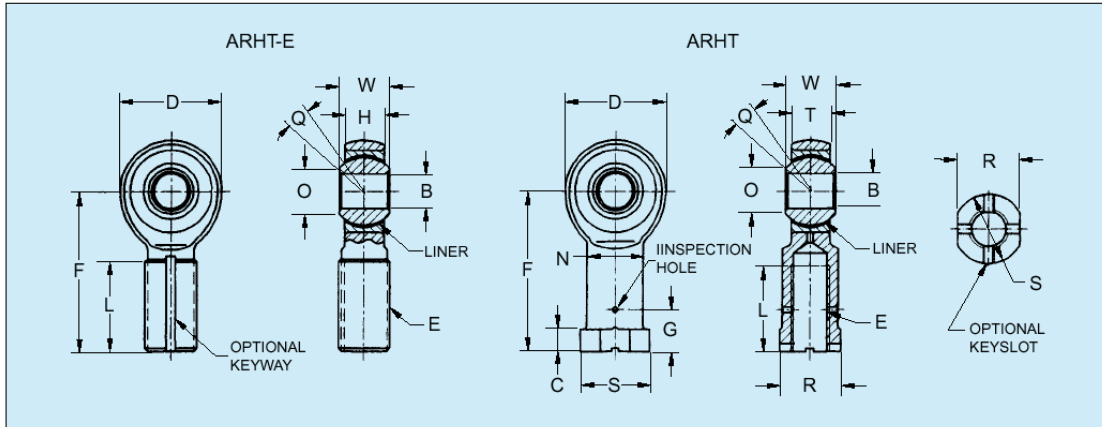

(L) Thread Length		(L) Thread Depth		(G) Drill C/L To End		(N) Shank Diameter		(S) Flange Diameter		(C) Flange Thickness		(R) Wrench Flat		No Load Rotational Breakaway Torque		Ultimate Static Radial Load		Axial Static Proof Load		Approx. Weight	
Inch	mm	Inch	mm	Inch	mm	Inch	mm	Inch	mm	In-lb	N-m	Inch	mm	In-lb	N-m	lbs	N	lbs	N	lbs	kg
.968	24.59	—	—	—	—	—	—	—	—	—	—	—	—	5-6	0.06-0.68	7550	33582	1000	4448	.067	0.030
—	—	.750	19.05	.375	9.52	.485	12.32	.562	14.27	.188	4.78	.500	12.70	1-10	0.11-1.13	9200	40922	1100	4893	.084	0.038
1.187	30.15	—	—	—	—	—	—	—	—	—	—	—	—	—	—	—	—	—	—	.095	0.043
—	—	.875	22.22	.437	11.10	.547	13.89	.625	15.88	.250	6.35	.562	14.27	1-10	0.11-1.13	10900	48483	1660	7384	.102	0.046
1.187	30.15	—	—	—	—	—	—	—	—	—	—	—	—	—	—	—	—	—	—	.140	0.064
—	—	1.000	25.40	.500	12.70	.610	15.49	.687	17.45	.250	6.35	.625	15.88	1-10	0.11-1.13	14050	62494	1850	8229	.160	0.073
1.281	32.54	—	—	—	—	—	—	—	—	—	—	—	—	—	—	—	—	—	—	.210	0.095
—	—	1.125	28.58	.562	14.27	.735	18.67	.875	22.22	.250	6.35	.750	19.05	1-10	0.11-1.13	23400	104083	2040	9074	.230	0.104
1.468	37.29	—	—	—	—	—	—	—	—	—	—	—	—	—	—	—	—	—	—	.330	0.150
—	—	1.250	31.75	.687	17.45	.860	21.84	1.000	25.40	.250	6.35	.875	22.22	1-10	0.11-1.13	26050	115870	2430	10809	.340	0.154
1.562	39.67	—	—	—	—	—	—	—	—	—	—	—	—	—	—	—	—	—	—	.480	0.218
—	—	1.375	34.92	.812	20.62	.985	25.02	1.125	28.58	.375	9.52	1.000	25.40	1-10	0.11-1.13	34500	153456	2810	12499	.490	0.222
1.687	42.85	—	—	—	—	—	—	—	—	—	—	—	—	—	—	—	—	—	—	.730	0.331
—	—	1.625	41.28	.937	23.80	1.110	28.19	1.250	31.75	.375	9.52	1.125	28.58	1-10	0.11-1.13					.740	0.336

Self-Lubricating Rod End Bearing

[ARHT-E, ARHT]

The information on this sheet is a continuation of the data on the previous sheet to cross reference the data, place two sheets next to each other