

2013

INSTRUMENTS



Digital Dash Display

The Stack LCD Motorsport Display is the next evolution of driver communication and data acquisition. The carbon composite housing is IP65 sealed against water and dust intrusion and will easily withstand 20g of continuous vibration and 50 g of shock. The 7" LCD panel ensures easy visibility under all circumstances with unmatched brightness and an optically bonded lens for extreme glare suppression. The display layout is configurable to your individual specifications. The system will accommodate four programmable data bus channels (2 CAN and 2 serial) in conjunction with discrete analog sensors and its integrated 3 Axis Accelerometer. Data collection can occur at up to 1 kHz and the internal memory allows for practically infinite recording time.

User definable warnings take advantage of super bright, multicolor LEDs placed around the perimeter of the chassis to alert the driver to critical onscreen information.



FEATURES

- Weight: 700g
- Dimensions - 211mm W x 132mm H x 35mm Deep (excl. connector)
- Carbon Composite Housing
- Supply Voltage: 8-18VDC
- Typical Power Consumption: 800 mA
- Single 37 way AS connector. (Mating Connector: Deutsch Autosport AS614-35SN)
- IP65 sealed
- Operating temperature range: -7°C to +80°C
- Humidity: 0-100% RH
- Continuous vibration up to 20g, Shock up to 50g



Code	Description
ST9918	Stack LCD Multi-Function Dash-Logger with DataPro Software

DISPLAY

- 7.0" TFT LCD panel
- Display Brightness: 1000 nit
- Resolution: 800 x 480.
- Onboard photo sensor for automatic brightness control.
- 16 User configurable multi-colour LED's
- Patented Predictive Lap Timing Display for Driver and Vehicle Development
- Display features perfectly rendered virtual analog needles, value display bands, digital value indicators for vehicle parameters and configurable full color text warning messages.
- 20 layers / screens / pages selected from 6 user- configurable templates (screens/instrument cluster designs/layouts), additional configurability supporting team selected graphics, parameter /instrument type and location, and size will be made available with future firmware and PC software releases.

INPUT/OUTPUT

- 12 Configurable user sensor inputs
 - 4 Configurable for Pulse, 0-5v, or resistive (0-526 Ω)
 - 8 Configurable for 0-5V
- Internal 3-axis accelerometer +/-6g
- Internal battery voltage
- 1 Dedicated Laptrigger Switch Input
- 4 Integrated Control Switches
- 4 Configurable I/O –
 - Control Switches
 - Pro Control Outputs – Drive external outputs for warning lights, relay control, etc.
- GPS Input (RS-232) - Mapping, Laptiming, etc.

COMMUNICATION

- 2 Configurable CAN ports - Up to 1 Mb/s (customer electronics package integration)
- 1 Configurable RS232 port: GPS
- 1 Ethernet port: (Configuration, Data Exchange, Firmware Upgrades)
- 1 USB port: (Data exchange, configuration, Copy and upload, firmware upgrades)

DATA LOGGING

- Max number of channels: 128
- Max sample 1,000 Hz
- Max total samples per second: 8,000
- Internal Memory: 4GB solid state internal
- Supplied with DataPro Analysis software
- Data Security: Pin code prevents data review by unauthorized personnel

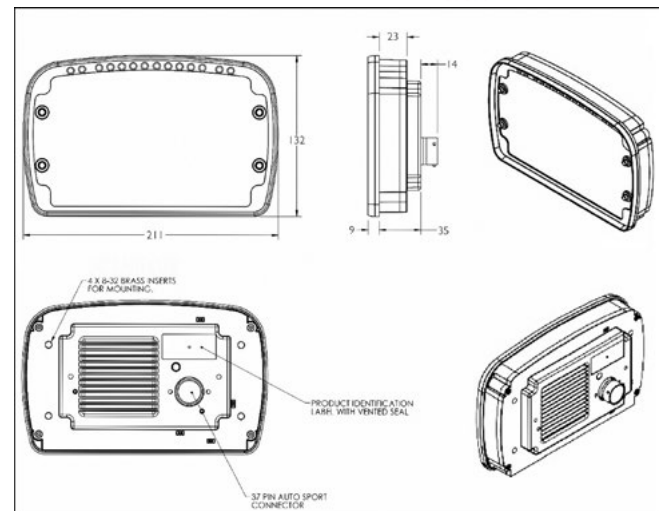



Analog Dash Display

The ST800 Dash Display System replaces all dashboard instruments - tachometer, oil pressure gauge, fuel pressure gauge, water temperature gauge, oil temperature gauge and voltmeter - with a single lightweight carbon composite display module. Chose the model after reading the list below.

OPTIONAL SEQUENTIAL SHIFT LIGHT MODULE

All Stack Dash Displays can drive the new Sequential Shift Light Module. Using the display menus, each of the 5 shift lights can be independently programmed to a specific RPM value, to provide complete flexibility. The Sequential Shift Light connects to dash harness with just 3 wires, and is ideal for dash-top mounting. (ST539)

LIGHTWEIGHT CARBON COMPOSITE HOUSING

Fully sealed against water and dust to IP67 for maximum reliability.

ULTRA BRIGHT WHITE LED BACKLIGHTING

Ensures clear viewing day and night.

ANALOGUE TACHOMETERS

The preferred choice of most racers.

DIAL FACES

Wide choice of dial faces.

SUPER-BRIGHT WARNING LIGHTS

The dash features a user configurable and built-in super-bright LED shift light. Additionally, an external dash top or panel mount shift light can be simply plugged into the dash harness

TRANSFLECTIVE LCD BACKLIT DISPLAY

Contrast improves when under bright illumination - clearly visible in bright sunlight.

DRIVER SELECTABLE LCD DISPLAY LAYERS

Selectable layers show different engine and performance information. Maximum peak value "Tell-Tale" memory is provided on Speed, Temperature and RPM parameters. Minimum peak value "Tell-Tale" are provided on Pressure and Voltage parameters.

USER CONFIGURABLE INPUTS, DISPLAYS AND ALARMS

INTELLIGENT ALARMS

Provided on all monitored parameters. Alarm levels are user adjustable to suit individual vehicle requirements. An internal alarm light is standard and an optional external light can be simply plugged into the dash harness.



ST539 - 5 Stage Sequential Shift Light Module

Code	Model	Scale	Unit	Dial face
ST8100-A-EC	RACE	0 - 8.000 rpm	EU	Black
ST8100-C-EC	RACE	0 - 3 - 8.000 rpm	EU	Black
ST8100-F-EC	RACE	0 - 4 - 10.000 rpm	EU	Black
ST8100-H-EC	RACE	0 - 3 - 10.500 rpm	EU	Black
ST8100-P-EC	RACE	0 - 6 - 13.000 rpm	EU	Black
ST8130-A-EC	STREET RACE	0 - 8.000 rpm	EU	Black
ST8130-F-EC	STREET RACE	0 - 4 - 10.000 rpm	EU	Black

Model	For Circuit race	For Rally race	For Street race	Total inputs	RPM	Fuel level	Speed (ST670)	Odometer & tripmeter	Oil pressure
ST800 RACE	√	√		8	√		OPTION		√
ST800 STREET RACE		√	√	8	√	√	√	√	√

Model	Fuel pressure	Water temperature	Oil temperature	Boost pressure	Battery voltage	Sequential shift light (ST539)	Lap Timing (ST539)
ST800 RACE	√	√	√		√	OPTION	OPTION
ST800 STREET RACE	OPTION	√	√		√	OPTION	OPTION

INTEGRATED DISPLAY



Code	Model	Scale	Dial face
ST700SR-J	ST700 STREET RACE	0 - 4 - 10.500 rpm	Black
ST700SR-K	ST700 STREET RACE	0 - 4 - 10.500 rpm	White
ST700SR-S	ST700 STREET RACE	0 - 6 - 15.000 rpm	Black
ST700SR-T	ST700 STREET RACE	0 - 6 - 15.000 rpm	White
ST700SR-A	ST700 STREET RACE	0 - 8.000 rpm	Black
ST700SR-B	ST700 STREET RACE	0 - 8.000 rpm	White

Sensors

Code	Sensor type	Description
ST762K	Standard	Temperature sensor 150° C - M10 thread
ST769	Solid State	Temperature sensor 150° C - M6x1 thread
ST740	Solid State	Boos pressure sensor from 0 to 3,5Bar - 1/8" NPTF thread



ST700 STREET RACE

The ST700 Dash Display systems integrate tachometer, sequential shift light and voltmeter in a single 80mm instrument. Standard options include speedometer, lap timer and two pressure or temperature. In addition the ST700 can be fitted with a range of performance options, including an acceleration timer, infrared lap timing system, split time memory and straight and corner speed readout.

Standard features include:

- Adjustable day & night backlighting levels to suit ambient light conditions.
- Fully sealed against water and dust to IP67.
- Peak value 'Tell-Tale' memory is provided on all monitored parameters.
- Configurable for all vehicle types and negative earth ignition systems.
- Supplied with mounting bracket, switch kit, separate professional wiring loom and manual.
- 1 year Competition Warranty

ALARM SYSTEM

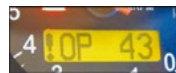

Alarms on all monitored parameters. The levels are fully configurable.

NEUTRAL ALARM



Simple connection of the instrument to the neutral sensor of any sequential gearbox. Requires neutral indicator (ST918051)

GEAR ALARM



Ultrabright LEDs configurable in 4 different modes: sequential, sequential with flashing, bar and simultaneous. Each LED is controlled individually.

CONFIGURABLE INPUTS



2 inputs for temperature and pressure sensors. Optional standar or solid state sensor are available.

Optionals

LAP TIMING SYSTEM



The lap timing receiver plugs into the standard dash wiring harness. When the vehicle passes the track side beacon the lap time "pops up" on the graphic display with an accuracy of 1/100th of a second. (ST546) optional.

LAP & SPLIT TIME MEMORY



This feature records 75 Lap and Split Times (if Split Timing is activated) and helps drivers evaluate their consistency. (ST7090) optional.

PERFORMANCE UPGRADE



It consists of the Split Time system and the Straight and Corner Speed readout options. Requires sensors:(ST670)+(ST546) (ST093) optional.

ACCELERATION CHRONO

Time of 1/4 mile / 400 meters, and acceleration and deceleration, with selectable speed. Requires sensor (ST670). (ST095) optional.

SPEEDOMETER & ODOMETER

Speedometer and odometer for road use, set in miles or kilometers Requires sensor (ST670). (ST7094) optional.

SPEED SENSOR

Sensor to be connected for showing the speed on the display. (ST670) optional

Model	Speed (ST670)	RPM	Battery	2 x config Channels*	Neutral indicator* (ST918051)	Lap Time (ST456)	Lap Memory (ST6090)	Perf. Upgrade (ST7093)	Accel. Timer (ST7095)	Odometer (ST7094)
ST700	OPTION	✓	✓	✓	OPTION	OPTION	OPTION	OPTION	OPTION	OPTION
ST700 STREET RACE	✓	✓	✓	✓	OPTION	OPTION	OPTION	OPTION	✓	✓

Please note: to use optional sensors is necessary to buy the ST91804 wiring. * Analog inputs require sensor (ST918049) ** Neutral indicator requires analog sensor (ST918049)

ACTION REPLAY TACHOS



ST400

Replay - on the tachometer - up to 25 minutes of RPM data. Review your shift points, choice of gear, gearing and use of the engine's power band. Diameter: 80 or 125 mm

Stack ST400 Key Features

- Ultra high accuracy guaranteed for life
- Proven Stack stepper motor movement - best performer for over 25 years
- Wide range of standard dial faces
- Separate wiring loom
- Exceptional durability
- External Shift Light available

Code	Scale	Display Ø
ST400-08	0 - 8.000 rpm	80 mm
ST400-0385	0 - 3 - 8.500 rpm	80 mm
ST400-04105	0 - 4 - 10.500 rpm	80 mm
ST400-0613	0 - 6 - 13.000 rpm	80 mm

Code	Scale	Display Ø
ST430-08	0 - 8.000 rpm	125 mm
ST430-010	0 - 10.000 rpm	125 mm

NB: ST430 tachos with 125mm Ø display can be mounted on standars 80mm Ø cut outs.





CLUBMAN

Stack tachometer suitable for all engines and ignition types. Fully water and dust proof. Features a maintenance free white LED backlight. Includes a comprehensive installation kit and manual.:

- Configurable for all negative earth and magneto ignition systems.
- Unique Stack Stepper-Motor Needle Movement.
- Unrivalled Digital Quartz accuracy guaranteed for life.
- Peak RPM 'Tell-Tale' memory.
- User adjustable shift light option (lamp not included).
- Exceptional reliability.
- Fully sealed against water and dust to IP67.
- Fits standard 80mm cut outs.
- Supplied with mounting bracket, switch kit, and user manual.
- Maintenance free White LED backlighting on all ST200 models.
- 1 year Competition Warranty.

Code	Scale	Dial face
ST200-08	0 - 8.000 rpm	Black
ST200-08W	0 - 8.000 rpm	White
ST200-04105	0 - 4 - 10.500 rpm	Black
ST200-0415W	0 - 4 - 15.000 rpm	White
ST200-0615	0 - 6 - 15.000 rpm	Black
ST200-0615W	0 - 6 - 15.000 rpm	White

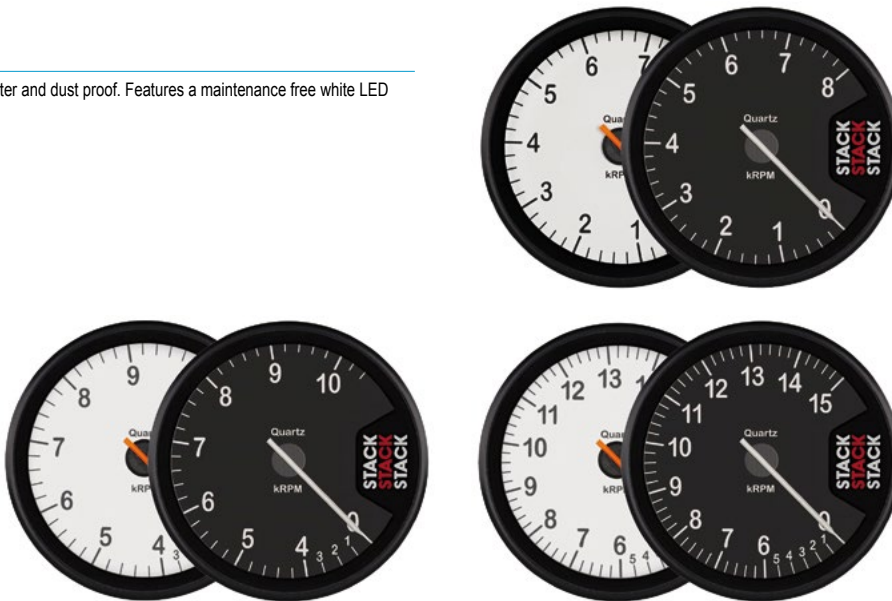

CLASSIC ST200 series

Clubman Classics range combine the best in modern electronic technology with "classic" styling. Diameter: 80 mm, no backlighting.



CLASSIC ST230 series

Diameter: 125 mm, no backlighting. NOTE: can be mounted in standard Ø 80 mm hole.

Code	Scale	Display Ø
ST200C-08	0 - 8.000 rpm	80 mm
ST200C-010	0 - 10.000 rpm	80 mm
ST200C-012	0 - 12.000 rpm	80 mm
ST230C-08	0 - 8.000 rpm	125 mm



CHRONOTRONIC

Faithfully Stack replicating Chronometric styling and movement, these tachometers are a direct replacement for original Chronometric tachometers, fitting directly into the original cut out.

- Accurate replica of original chronometric tachometer
- Solid-state electronics for exceptional reliability
- Stepper-motor needle movement re-creates 'chronometric' movement
- Chrome style bezel
- Maintenance-free white LED backlighting
- 0-10000 RPM dial face
- Peak RPM Tell Tale Memory
- Configurable for all negative earth ignition systems and magneto ignition systems
- 12 Months Competition Warranty
- Supplied with mounting bracket, switch kit and manual

Code	Scale	Display Ø
ST901096	0 - 10.000 rpm	80 mm



SPORT

Low-cost tachometer, compatible with ST38xx speedometers
Air core based in-dash performance tachometer matched to ST38xx speedometers and existing 52mm gauges
Note: this is NOT a stepper motor needle movement.
- Lower cost and reduced feature set from ST200 Clubman models (tach only, not sealed, no shift light or peak memory)
- Supports most 2-8 cylinder applications
- 3 dial face colors (black, white, Stack red)
- Two scales, 0-8k linear and 0-10k linear
- Through dial White LED backlighting
- Will incorporate the black case and 8 terminal connectors
- Intended for performance, tuning, and track day customers seeking to create a fully matched set of instruments within the Stack line



Code	Scale	Dial face
ST100-08	0 - 8.000 rpm	Black
ST100-08W	0 - 8.000 rpm	White
ST100-08R	0 - 8.000 rpm	Red
ST100-010	0 - 10.000 rpm	Black
ST100-010W	0 - 10.000 rpm	White
ST100-010R	0 - 10.000 rpm	Red

SPEEDOMETERS



Speedometers

Compatible with most OEM vehicle speed sensors, as well as aftermarket speed pulse generators - plus Stack's ST668 wheel speed sensor. The instrument includes back-lit Odometer and two resettable Tripmeter displays.

- Fully user programmable.
- LCD odometer with a re-settable trip displays.
- Maintenance free through the dial white LED backlighting.
- LED illuminated needle for maximum visibility.
- 80mm visible dial dimension, requires 85mm cutout.
- Available in black or white dial faces.
- Optional sensors available for some cable-drive applications.
- Configurable for all negative earth ignition systems and magneto ignition systems.
- 12 months Competition Warranty. Supplied with manual.

Code	Scale	Dial face
ST3802	0 - 260 Km/h	Black
ST3852	0 - 260 Km/h	White
ST3804	0 - 290 Km/h	Black



WIDE-BAND AIR-FUEL (LAMBDA)



LED 2018

New dual digital and radial LED displays provide accurate real-time readout of either air/fuel ratio or lambda (user-selectable). Diameter: 52 mm

- A 0-5Volt analogue output can be connected to a data-logger or to an ECU to provide real-time closed-loop feedback for improved mapping.
- Supplied complete with wiring harness and includes Bosch LSU 4.9 sensor.
- User-selectable Air/Fuel or Lambda real time display
- Programmable Alarm warns of dangerous lean condition
- Peak Recall of leanest value during last run
- Suitable for all fuel types with AFR from 6:1 to 20:1 (not recommended for leaded fuel)
- Add serial data and Pro-Control outputs, Add programmable display response update

Code	Dial face
ST3403	Black
ST3404	White



DIGITAL BOOST PRESSURE



DIGITAL DISPLAY

52mm Boost Controller Gauge 30 PSI / 2 Bar Applications - Digital RPM display

- Digital display with radial LED matched to current Wideband Lambda Arrangement
- Modifies mechanical waste gate duty cycle to achieve higher boost pressures than in place controls would otherwise allow
- Push button programming
- All inclusive kit consists of gauge, wire loom, MAP sensor and 3 port solenoid valve
- Suitable for use with single and twin/bi turbocharged applications
- 4 Programmable control strategies: High Boost, Low Boost, RPM based mapping, Gear based mapping
- MAP, RPM, and VehicleSpeed inputs
- Intelligent gear capture, Peak tell-tale memory
- Pro-Control Output and Input
- 0-5V datalogger output
- Selectable Units PSI, BAR, kPa
- Optional barometric compensation mode to adjust for changing atmospheric conditions.

Code	Dial face
ST3412	Black
ST3462	White



MECHANICAL COMBINED

Racetech 52mm mechanical combined gauges:

Oil pressure and water temperature. Scales: 0-100psi and 30-110°C.

Oil pressure, oil temperature. Scale: 0-100psi, 0-140°C.

Generic pressure and temperature. Scales: 0-160psi and 0-120°C.

Black face, white letters, black bezel. 1/8BSP union on the pressure gauge. The capillary tube for the temperature reading is supplied with a 3/8BSP male to male adaptor.



RACETECH

Oil pressure and Water Temperature

Code	Temp. Wire	Pressure Thread	Backlight
PT1011B7	7'	1/8 BSP	No
PT1011B9	9'	1/8 BSP	No
PT1011BA7	7'	-03	No
PT1011BAL12	12'	-03	Yes
PT1011BAL7	7'	-03	Yes
PT1011BAL9	9'	-03	Yes
PT1011BL12	12'	1/8 BSP	Yes
PT1011BL7	7'	1/8 BSP	Yes
PT1011BL9	9'	1/8 BSP	Yes



RACETECH

Oil pressure and Oil temperature

Code	Temp. Wire	Pressure Thread	Backlight
PT1014B7	7'	1/8 BSP	No
PT1014B9	9'	1/8 BSP	No
PT1014BA7	7'	-03	Yes
PT1014BA9	9'	-03	No
PT1014BAL12	12'	-03	Yes
PT1014BAL9	9'	-03	Yes
PT1014BL12	12'	1/8 BSP	Yes
PT1014BL7	7'	1/8 BSP	Yes
PT1014BL9	9'	1/8 BSP	Yes



RACETECH

Generic pressure and temperature

Code	Temp. Wire	Pressure Thread	Backlight
PT1612B7	7'	1/8 BSP	No
PT1612B9	9'	1/8 BSP	No
PT1612BA7	7'	-03	No
PT1612BA9	9'	-03	No
PT1612BAL12	12'	-03	Yes
PT1612BAL9	9'	-03	Yes
PT1612BL12	12'	1/8 BSP	Yes
PT1612BL7	7'	1/8 BSP	Yes
PT1612BL9	9'	1/8 BSP	Yes

PROCONTROL

Stack's Pro-Control range of Professional Stepper Motor Analogue Gauges are user configurable with Maximum/Minimum alarms which can be set with one of seven different colours to indicate status.

- 52mm diameter
- Peak "tell-tale" Memory - Max temps, Min pressures
- Configurable max and min full dial alarm warnings
- Configurable Pro-Control output for activating accessories eg. fans, pumps, etc (requires relay)
- 270° full sweep movement for excellent readability
- Temperature gauges with built-in "fan controller"
- Pressure gauges with built-in "pump controller"
- 0-5 Volt analogue output for data logger or ECU (except EGT and Fuel Level gauges)
- Configurable backlight colour
- Black dialface when powered off
- 7 Colour LED through-the-dial backlighting
- Better than 2% accuracy.

All ProControl gauges (except Fuel Level and Voltmeter) come complete with wiring harness and associated solid-state sensor.

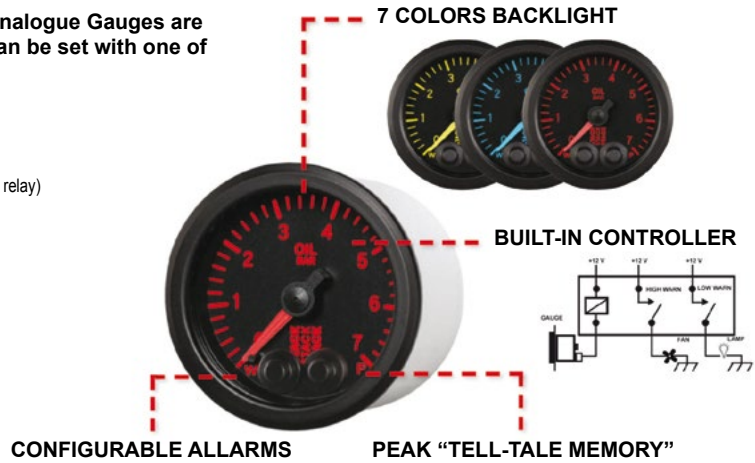

Oil pressure

Code	Scale
ST3501	0 - 7 bar
ST3502	0 - 100 psi



Fuel pressure

Code	Scale
ST3503	0 - 1 bar
ST3504	0 - 15 psi
ST3505	0 - 7 bar
ST3506	0 - 100 psi



Water temperature

Code	Scale
ST3507	40 - 120°C
ST3508	100 - 260°F



Oil temperature

Code	Scale
ST3509	40 - 140°C
ST3510	100 - 280°F



Boost pressure

Code	Scale
ST3511	from -1.0 to +2.0 Bar
ST3512	from -30 to +30 psi



Exhaust temp.

Code	Scale
ST3513	0 - 1100°C
ST3514	0 - 2000°F



Fuel level

Code	Scale
ST3515	programmable
Wiring harness & sensor not included	



Voltmeter

Code	Scale
ST3516	8 - 18V
Wiring harness & sensor not included	

PROFESSIONAL STEP-MOTOR

They combine digital microprocessor accuracy with a high-precision stepper motor needle movement.

- 52mm diameter
- Fast, smooth stepper motor needle drive
- 270° full sweep movement for excellent readability
- Remotely mounted solid-state sensors keep hazardous fluids in the engine compartment
- Better than 2% accuracy
- All-electronic design for maximum reliability
- White LED through-the-dial backlighting
- Black dialface with White LED illuminated needle or White dialface with Orange LED illuminated needle



Oil pressure



Fuel pressure



Water temperature



Oil temperature



Boost pressure

Code	Scale	Dial Face
ST3301	0 - 7 bar	Black
ST3351	0 - 7 bar	White
ST3302	0 - 100 psi	Black
ST3352	0 - 100 psi	White

Code	Scale	Dial Face
ST3303	0 - 1 bar	Black
ST3353	0 - 1 bar	White
ST3304	0 - 15 psi	Black
ST3305	0 - 7 bar	Black
ST3355	0 - 7 bar	White
ST3306	0 - 100 psi	Black
ST3356	0 - 100 psi	White

Code	Scale	Dial Face
ST3307	40 - 120°C	Black
ST3357	40 - 120°C	White
ST3308	100 - 260°F	Black

Code	Scale	Dial Face
ST3309	40 - 140°C	Black
ST3359	40 - 140°C	White
ST3310	100 - 280°F	Black

Code	Scale	Dial Face
ST3311	from -1.0 to +2.0 bar	Black
ST3361	from -1.0 to +2.0 bar	White
ST3312	from -30 to +30 psi	Black



Clock

Code	Scale	Dial Face
ST3317	12	Black
ST3367	12	White



Exhaust temp.

Code	Scale	Dial Face
ST3313	0 - 1100°C	Black
ST3363	0 - 1100°C	White
ST3314	0 - 2000°F	Black



Fuel level

Code	Dial Face
ST3315	Black
ST3365	White
	Programmable



Volmeter

Code	Scale	Dial Face
ST3316	8 - 18V	Black
ST3366	8 - 18V	White

ELECTRICAL

Easy to install, white lit dial and illuminated needle, supplied with sensor (wires not included).

- 90° sweep • simple 3-wire installation • 52mm diameter.



Oil pressure

Code	Scale	Dial face
ST3201	0 - 7 bar	Black
ST3251	0 - 7 bar	White
ST3202	0 - 100 psi	Black
ST3252	0 - 100 psi	White



Water temperature

Code	Scale	Dial face
ST3207	40 - 120°C	Black
ST3257	40 - 120°C	White
ST3208	120 - 250°F	Black



Oil temperature

Code	Scale	Dial face
ST3209	60 - 150°C	Black
ST3259	60 - 150°C	White
ST3210	140 - 300°F	Black



Volmeter

Code	Scale	Dial face
ST3216	8 - 18V	Black
ST3266	8 - 18V	White

PROFESSIONAL STEP-MOTOR CLASSIC

They combine Professional stepper-motor features with a CLASSIC design.

- Fast, smooth stepper motor needle drive
- 270° full sweep movement for excellent readability
- White LED through-the-dial backlighting
- 52mm diameter



Oil pressure

Code	Scale	Dial Face
ST3301C	from 0 to 7 bar	Black
ST3302C	from 0 to 100 psi	Black



Fuel pressure

Code	Scale	Dial Face
ST3303C	from 0 to 1 bar	Black
ST3304C	from 0 to 15 psi	Black
ST3305C	from 0 to 7 bar	Black
ST3306C	from 0 to 100 psi	Black



Water temperature

Code	Scale	Dial Face
ST3307C	40 - 120°C	Black
ST3308C	100 - 260°F	Black



Oil temperature

Code	Scale	Dial Face
ST3309C	40 - 140°C	Black
ST3310C	100 - 280°F	Black



Boost pressure

Code	Scale	Dial Face
ST3311C	from -1.0 to +2.0 bar	Black
ST3312C	from -30 to +30 psi	Black



Clock

Code	Scale	Dial Face
ST3317C	12	Black



Fuel level

Code	Dial Face
ST3315C	Black
	Programmable



Voltmeter

Code	Scale	Dial Face
ST3316C	8 - 18V	Black

MECHANICAL

This range of Stack gauges have been specifically designed for vehicles with no or low powered supply systems.

- 52mm diameter
- Black dialface with White LED illuminated needle or White dialface with Orange LED illuminated needle
- Bronze bourdon tube 270° sweep movement
- Mechanical gauges do not require 12V power to operate. They make direct physical contact with the item they are reading. They do this through tubing or lines, which eliminates the need for electric signals.
- Ideal for vehicles that operate on voltages other than 12V, with no voltage at all (magneto applications) or operate on a battery with no generator.
- Note: 12 volt supply is needed if backlighting required.



Oil pressure

Code	Scale	Dial Face
ST3101	0 - 7 bar	Black
ST3102	0 - 100 psi	Black



Water temperature

Code	Scale	Dial Face
ST3107	50 - 115°C	Black
ST3108	120 - 240°F	Black



Boost pressure

Code	Scale	Dial Face
ST3111	from -1.0 to +2.0 bar	Black
ST3161	from -1.0 to +2.0 bar	White
ST3112	from -30 to +30 psi	Black
ST3162	from -30 to +30 psi	White

GAUGE MOUNTS



Code	Description
ST262121	Stack Pedestal Auxiliary Gauge Mount - carbon



Code	Description
ST264803	Stack Roll Cage Gauge Mount



Code	Description
ST264809	Stack Pedestal Auxiliary Gauge Mount - standard

WIRING HARNESES FOR Ø 52 MM GAUGES

Code	Description
ST265226	Replacement Wiring Harness for Fluid Temp. Gauges STACK ST3300
ST265227	Replacement Wiring Harness for Fluid Pressure gauges STACK ST3300
ST265229	Replacement Wiring Harness for Boost gauges STACK ST3300
ST265232	Replacement Wiring Harness for Wideband Lambda gauge STACK ST3400
ST265233	Replacement Wiring Harness for Fuel Level gauge STACK ST3300
ST265234	Replacement Wiring Harness for Voltmeter gauge STACK ST3300
ST265251	Replacement EGT Probe & Wiring Harness for EGT gauges STACK ST3300
ST265294	Replacement Wiring Harness for Fluid Pressure gauges STACK ST3500
ST265295	Replacement Wiring Harness for Fluid Temp. Gauges STACK ST3500
ST265296	Replacement Wiring Harness for Boost gauges STACK ST3500
ST265297	Replacement Wiring Harness for Fuel Level gauge STACK ST3500
ST265298	Replacement Wiring Harness for Voltmeter gauge STACK ST3500
ST265299	Replacement EGT Probe & Wiring Harness for EGT gauges STACK ST3500



Wiring harnesses for 52 mm

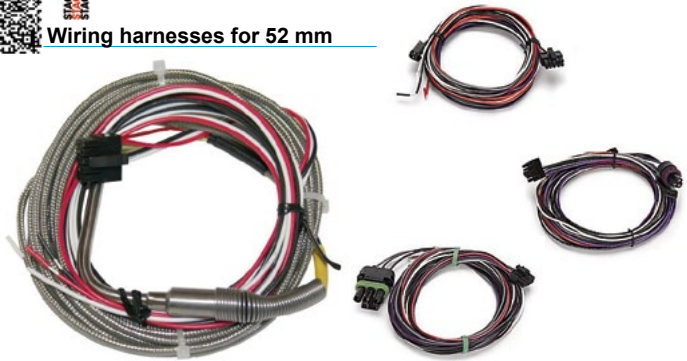

SENSORS FOR Ø 52 MM GAUGES



Gauge code	Description	Sensor code
ST3201	GAUGE, OIL PRESS, ELECTRIC	ST262242
ST3202	GAUGE, OIL PRESS, ELECTRIC	ST262242
ST3207	GAUGE, WATER TEMP, ELECTRIC	ST262256
ST3208	GAUGE, WATER TEMP, ELECTRIC	ST262258
ST3209	GAUGE, OIL TEMP, ELECTRIC	ST262256
ST3210	GAUGE, OIL TEMP, ELECTRIC	ST262258
ST3251	GAUGE, OIL PRESS, ELECTRIC	ST262242
ST3252	GAUGE, OIL PRESS, ELECTRIC	ST262242
ST3257	GAUGE, WATER TEMP, ELECTRIC	ST262256
ST3258	GAUGE, WATER TEMP, ELECTRIC	ST262258
ST3259	GAUGE, OIL TEMP, ELECTRIC	ST262256
ST3260	GAUGE, OIL TEMP, ELECTRIC	ST262258
ST3301	GAUGE, OIL PRESS, PRO STEPPER MOTOR	ST262246
ST3301C	GAUGE, OIL PRESS, PRO STEPPER MOTOR	ST262246
ST3302	GAUGE, OIL PRESS, PRO STEPPER MOTOR	ST262246
ST3302C	GAUGE, OIL PRESS, PRO STEPPER MOTOR	ST262246
ST3303	GAUGE, FUEL PRESS, PRO STEPPER MOTOR	ST262245
ST3303C	GAUGE, FUEL PRESS, PRO STEPPER MOTOR	ST262245
ST3304	GAUGE, FUEL PRESS, PRO STEPPER MOTOR	ST262245
ST3304C	GAUGE, FUEL PRESS, PRO STEPPER MOTOR	ST262245
ST3305	GAUGE, FUEL PRESS, PRO STEPPER MOTOR	ST262246
ST3305C	GAUGE, FUEL PRESS, PRO STEPPER MOTOR	ST262246
ST3306	GAUGE, FUEL PRESS, PRO STEPPER MOTOR	ST262246
ST3306C	GAUGE, FUEL PRESS, PRO STEPPER MOTOR	ST262246
ST3307	GAUGE, WATER TEMP, PRO STEPPER MOTOR	ST262252
ST3307C	GAUGE, WATER TEMP, PRO STEPPER MOTOR	ST262252
ST3308	GAUGE, WATER TEMP, PRO STEPPER MOTOR	ST262252
ST3308C	GAUGE, WATER TEMP, PRO STEPPER MOTOR	ST262252
ST3309	GAUGE, OIL TEMP, PRO STEPPER MOTOR	ST262252
ST3309C	GAUGE, OIL TEMP, PRO STEPPER MOTOR	ST262252
ST3310	GAUGE, OIL TEMP, PRO STEPPER MOTOR	ST262252

Gauge code	Description	Sensor code
ST3310C	GAUGE, OIL TEMP, PRO STEPPER MOTOR	ST262252
ST3311	GAUGE, BOOST, PRO STEPPER MOTOR	ST262249
ST3311C	GAUGE, BOOST, PRO STEPPER MOTOR	ST262249
ST3312	GAUGE, BOOST, PRO STEPPER MOTOR	ST262249
ST3312C	GAUGE, BOOST, PRO STEPPER MOTOR	ST262249
ST3351	GAUGE, OIL PRESS, PRO STEPPER MOTOR	ST262246
ST3352	GAUGE, OIL PRESS, PRO STEPPER MOTOR	ST262246
ST3353	GAUGE, FUEL PRESS, PRO STEPPER MOTOR	ST262245
ST3354	GAUGE, FUEL PRESS, PRO STEPPER MOTOR	ST262245
ST3355	GAUGE, FUEL PRESS, PRO STEPPER MOTOR	ST262246
ST3356	GAUGE, FUEL PRESS, PRO STEPPER MOTOR	ST262246
ST3357	GAUGE, WATER TEMP, PRO STEPPER MOTOR	ST262252
ST3358	GAUGE, WATER TEMP, PRO STEPPER MOTOR	ST262252
ST3359	GAUGE, OIL TEMP, PRO STEPPER MOTOR	ST262252
ST3360	GAUGE, OIL TEMP, PRO STEPPER MOTOR	ST262252
ST3361	GAUGE, BOOST PRESS, PRO STEPPER MOTOR	ST262249
ST3362	GAUGE, BOOST PRESS, PRO STEPPER MOTOR	ST262249
ST3403	GAUGE, WIDEBAND AIR-FUEL RATIO (LAMBDA), PRO-CONTROL	ST265316
ST3404	GAUGE, WIDEBAND AIR-FUEL RATIO (LAMBDA), PRO-CONTROL	ST265316
ST3501	GAUGE, OIL PRESS, PRO-CONTROL	ST262246
ST3502	GAUGE, OIL PRESS, PRO-CONTROL	ST262246
ST3503	GAUGE, FUEL PRESS, PRO-CONTROL	ST262245
ST3504	GAUGE, FUEL PRESS, PRO-CONTROL	ST262245
ST3505	GAUGE, FUEL PRESS, PRO-CONTROL	ST262246
ST3506	GAUGE, FUEL PRESS, PRO-CONTROL	ST262246
ST3507	GAUGE, WATER TEMP, PRO-CONTROL	ST262252
ST3508	GAUGE, WATER TEMP, PRO-CONTROL	ST262252
ST3509	GAUGE, OIL TEMP, PRO-CONTROL	ST262252
ST3510	GAUGE, OIL TEMP, PRO-CONTROL	ST262252
ST3511	GAUGE, BOOST PRESS, PRO-CONTROL	ST262249
ST3512	GAUGE, BOOST PRESS, PRO-CONTROL	ST262249

SENSORS FOR MULTIFUNCTION DISPLAYS



Sensors for multifunction displays

Code	Description
ST492	Pulse Amplifier (e.g. Gearbox Sensor Amplifier)



Sensors for multifunction displays

Code	Description
ST668	Proximity Sensor for ST3800 Speedometers



Sensors for multifunction displays

Code	Description
ST670	Proximity Speed Sensor



Sensors for multifunction displays

Code	Description
ST745K	0-150 psi Fluid Pressure Sensor (1/8 NPTF)+lead



Sensors for multifunction displays

Code	Description
ST760K	150 °C Fluid Temp. Sensor (1/8 BSPT) + lead



Sensors for multifunction displays

Code	Description
ST762K	150 °C Fluid Temp. Sensor (M10) + lead



Sensors for multifunction displays

Code	Description
ST764K	150 °C Fluid Temp. Sensor (1/8 NPTF) + lead



Sensors for multifunction displays

Code	Description
ST769	-20 to 150 deg C temperature sensor (M6x1)



Sensors for multifunction displays

Code	Description
ST740	0 to 3.5 bar/ 50 psi boost sensor (1/8"NPTF) (replacement only)



Sensors for multifunction displays

Code	Description
ST742K	0-30 psi Fluid Pressure Sensor (1/8 NPTF)+ lead

WIRING HARNESSES FOR MULTIFUNCTION GAUGES

Code	Description
ST584	Installation Kit for ST400 Tachometer
ST594	Loom for ST400/430/C
ST872-006	Loom for 2005-2006 Spec. ST8100/8130/8110/8120
ST872-806	Loom for 2005-2006 Spec. ST8110SR
ST884	Extender harness Kit (2x0.7m;2x1.4m;1x2.1m)
ST913029	Installation Kit for Clubman Tachometer
ST918020	0.7 m Extension Harness
ST918021	1.4 m Extension Harness
ST918022	2.1 m - Extension Harness
ST918039	Main loom for ST500 & ST700
ST918040	ST670 RPM adapter (ST670 not included)
ST918049	Sensor loom for ST700



Wiring harnesses for multifunction



LAP TIMING SYSTEMS



Lap Timing system

Lap Timing System
 The lap timing receiver simply plugs into the standard dash wiring harness.
 When the vehicle passes the track side beacon the lap time "pops up" in the graphic display with an accuracy of 1/100th of a second.
 At any time the driver can select the Lap Time Display layer to show the Last Lap Time, Best Lap Time and number of laps driven.

Code	Description
ST546	Infrared Lap Timing System receiver & beacon



Lap Timing receiver

Code	Description
ST543	Infrared Lap Timing System receiver only



Lap Timing trackside beacon

Code	Description
ST544	Infrared Lap Timing System trackside beacon only



SHIFT LIGHTS & GEAR INDICATORS

Code	Description
ST532	Dash Top Shift Light - amber
ST533	Dash Top Shift Light - white
ST534	Dash Top Shift Light - red
ST536	Panel Mount Shift Light - white
ST537	Panel Mount Shift Light - red
ST538	Panel Mount Shift Light - amber
ST539	5 Stage Sequential Shift Light Module



ST532



ST533



ST534



ST539



ST536



ST537



ST538



Shift Lights & Gear Indicators

The new and improved Cartek Shift Light incorporates 8 full colour, high intensity LED's and now includes an additional alarm signal input which will flash a different display pattern to let the driver know there is a fault with the vehicle.

You can configure:

- The lower and upper RPM settings with or without the engine running
- Select from several LED display patterns for the Shift Light sequence
- The brightness of the LED's.

The Cartek Shift Light is designed to work with most ignition systems and tach signals.

The unit is fully sealed for open-cockpit cars and motorcycles.

Size:W75mm x H18mm

Code	Description
CK-LS-CL	Sequential Shift Light Module CARTEK



ACCESSORIES



Switch kits

Code	Description
ST510	2 Switch kit
ST511	3 Switch kit
ST514	4 Switch kit (without connectors)



Thread adapters

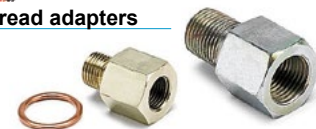

Code	Description
ST154003	1/8 NPTF to M10 adapter
ST154006	1/8 NPTF to 1/8 BSPT adapter
ST154012	M6x1 to M10x1 adapter
ST154013	M6x1 to 1/8 NPTF adapter
ST154016	1/8 BSP to 1/8 NPTF adapter