

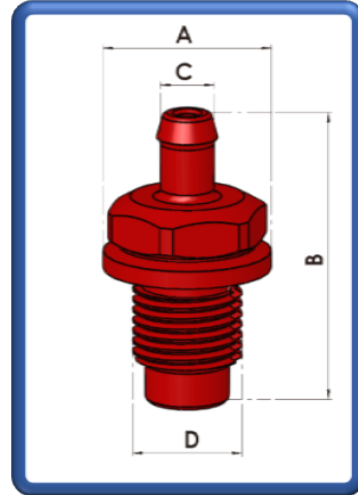

Tank Mount Valves

Vent Valve Rollover, Tank Mount, Ø7.0 – 9/16” UNF Thread.
Part Number: CF-AA-007 (TRV67)



Specifications:

Fixing Arrangement:

Applications:

Compatibilities:

Finish:

Weight:

Flow Capacity:

Valve Placement:

Ø7.0mm Standpipe (Top)
9/16” UNF Thread (Bottom)
Motorsport, Automotive, Marine & General
Operation Temperature -40°C to +80°C
Anodised Red
14.0 grams
0.66 litre/second
Vertical ±10°

Materials:

Bodies:

O-Ring & Gasket:

Internal Flootation Ball:

Secondary Internal Ball:

Retention:

Aluminium Alloy 6082/T6
Viton A (FPM or FKM)
HDPE plastic (Green)
Stainless Steel 316
Brass

Dimensions:

Outside Diameter A:

Height B:

Bolts Circle Diameter C:

Depth D:

Across Flats:

22.0mm

45.0mm

Ø7.0mm Spigot

9/16” x 18UNF Thread

19.0mm

Optional('s):

For extreme Fuel usage, please contact a Newton Representative.

Fluid Containment – When It Matters

Tell: +4420 8594 7990 / Fax: +4420 8594 7989 / www.newton-equipment.com / info@newton-equipment.com

Registered in England. 6 Orwell Close/ Fairview Ind. Park/ Rainham/ Essex/ RM13 8UB