

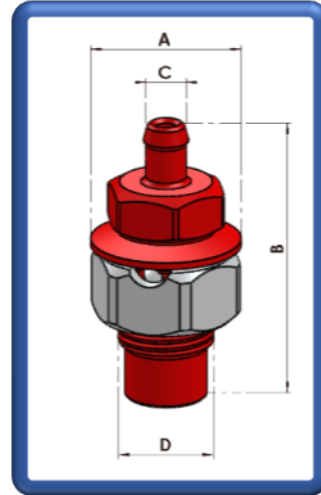

Tank Mount Valves

Vent Valve Rollover, Tank Mount, Ø5.0 – 7/16" UNF Thread.
Part Number: CF-AA-005 (TRV45)



Specifications:

Fixing Arrangement:

Ø5.0 Standpipe (Top)

7/16" UNF Thread (Bottom)

Applications:

Motorsport, Automotive, Marine & General

Compatibilities:

Operation Temperature -40°C to +80°C

Finish:

Anodised Red

Weight:

9.5 grams

Flow Capacity:

0.6 litre/second

Valve Placement:

Vertical ±10°

Materials:

Bodies:

Aluminium Alloy 6082/T6

O-Ring & Gasket:

Viton A (FPM or FKM)

Internal Floatation Ball:

HDPE plastic (Green)

Secondary Internal Ball:

Stainless Steel 316

Retention:

Brass

Dimensions:

Outside Diameter A:

17.5mm

Height B:

33.5mm

Bolts Circle Diameter C:

Ø5.0 Spigot

Depth D:

7/16" x 20UNF Thread

Across Flats:

12.6mm

Optional('s):

For extreme Fuel usage, please contact a Newton Representative.

Fluid Containment – When It Matters

Tell: +4420 8594 7990 / Fax: +4420 8594 7989 / www.newton-equipment.com / info@newton-equipment.com

Registered in England. 6 Orwell Close/ Fairview Ind. Park/ Rainham/ Essex/ RM13 8UB