

# B1 INSTALLATION DRAWING

IF THIS DOCUMENT IS PRINTED IN HARDCOPY, IT IS FOR INFORMATION USE ONLY AND THEREFORE IS NOT SUBJECT TO UPDATING CONTROLS. ALWAYS REFER TO SOLIDWORKS VIEWER FOR LATEST ISSUE

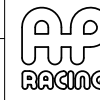

THIS DRAWING IS CONFIDENTIAL AND IS SUPPLIED ON THE EXPRESS CONDITION THAT IT SHALL NOT BE LOANED OR COPIED OR DISCLOSED TO ANY OTHER PERSON OR USED FOR ANY OTHER PURPOSE WITHOUT THE WRITTEN CONSENT OF AP RACING LTD.



AP Racing  
Wheler Road  
Coventry  
CV3 4LB  
Tel: +44 024 7663 9595  
Fax: +44 024 7663 9559  
e-mail: sales@apracings.co.uk  
Web site: HTTP://www.apracings.com

© AP Racing Ltd. 2019

Alterations

Date & No. Particulars Zone # Initials

01 14/05/19 87824 FIRST ISSUE # THS

02 23/05/19 87824\_04 SHEET 1 MIN STACK UPDATED GUIDANCE MTG BOLT TIGHTENING TORQUE ADDED SHEET 3 COATED ADDED TO PISTON DESCRIPTION # THS

## CP7269-2 / 3S7L SPECIFICATION

**GENERAL DESCRIPTION**  
6 PISTON DIFFERENTIAL BORE CALIPER TO SUIT UP TO Ø390x36mm IRON DISC WITH A FIXED BRIDGE DESIGN.

**TYPICAL APPLICATION - GT**

CALIPER SPECIFICATION	
BORE SIZE	CEJ (27.00 x 31.75 x 38.10) (1.063" x 1.25" x 1.50")
PISTON AREA (TOTAL)	50.08cm <sup>2</sup>
DISC DIAMETER MAX	390.00
DISC THICKNESS MAX	36.00
DISC THICKNESS MIN (WORN CONDITION)	34.50 (DIFFERENTIAL WEAR NOT TO EXCEED 0.5mm SIDE TO SIDE)
PAD FAMILY	CP6210 D64
PAD THICKNESS MAX	30.00
PAD THICKNESS MIN	6.00
MIN STACK	46.50
HYDRAULIC FEED	M10x1.0 15.0 THREAD DEPTH
DUCTING MOUNTS	M4x0.70 8.0 THREAD DEPTH
SCRAPER MOUNTS	M4x0.70 8.0 THREAD DEPTH
DRY WEIGHT (WITHOUT PADS)	3.03kg
EFFECTIVE RADIUS (ON Ø390 DISC)	164.00
'PL' DIMENSION (TOP OF PAD FRICTION MATERIAL TO CALIPER MOUNTING FACE)	63.50
'C' DIMENSION (CALIPER OFFSET)	42.00
'U' DIMENSION (UPRIGHT MOUNTING)	131.5 U = (DISC Ø/2) - PL
TIGHTENING TORQUES	BLEED SCREW: 17Nm HYDRAULIC FEED: 25Nm PAD LEDGE SCREWS: 4Nm TYPICAL M12 MOUNTING BOLT: 65Nm (GUIDANCE ONLY)

CALIPER POSITIONING	
RHT	RIGHT HAND TRAILING (BEHIND AXLE)
LHT	LEFT HAND TRAILING (BEHIND AXLE)

PART NUMBERING CONVENTION	
<b>PART NUMBER</b>	<b>DESCRIPTION</b>
CP7269-2S7L	RHT - SIDE FEED - 7lb AKB SPRING - STAINLESS PISTONS
CP7269-3S7L	LHT - SIDE FEED - 7lb AKB SPRING - STAINLESS PISTONS

**INSTALLATION INFORMATION**  
THE CALIPER IS DESIGNED SO THAT THE DISC WILL BE MOUNTED CENTRALLY WITHIN A TOLERANCE OF ±0.50mm.  
THE CALIPER IS TO BE MOUNTED IN THE TRAILING POSITION ONLY, ±15° FROM THE VERTICAL.  
THE DIAMETRICAL CLEARANCE BETWEEN THE DISC OUTSIDE DIAMETER AND THE PATHWAY SHOULD BE 2.50mm NOMINALLY.

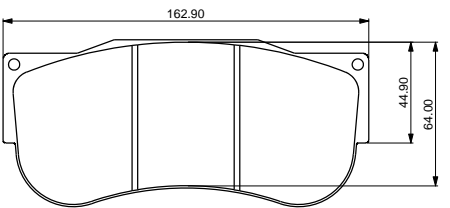

CP6210D64 IRON PAD	
PAD AREA	SLOTTED - 90.5cm <sup>2</sup> FULL AREA - 93.7cm <sup>2</sup>

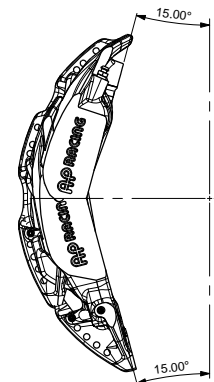
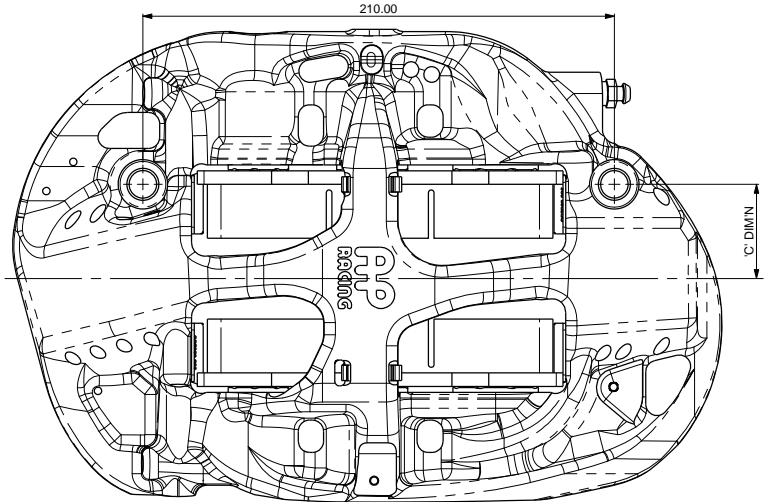
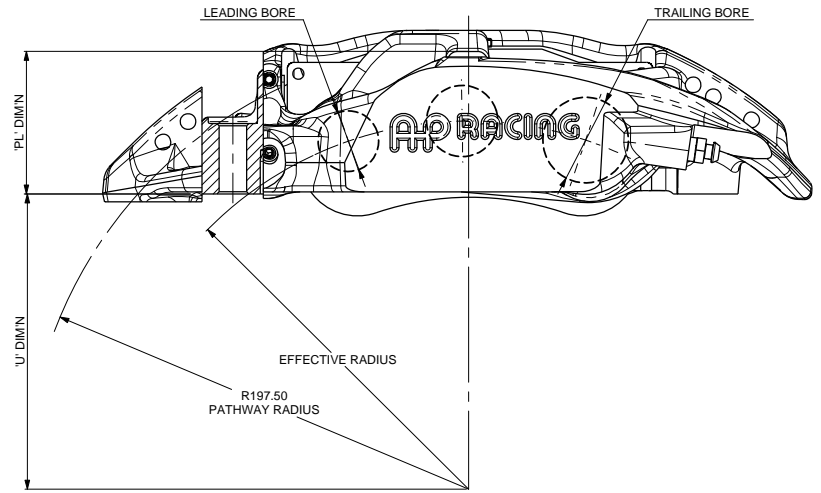

**OPTIMUM BLEED POSITION**  
FOR OPTIMUM BLEED, THE CALIPER SHOULD BE INSTALLED IN THE TRAILING POSITION ±15° FROM THE VERTICAL AS SHOWN.

SCALE 1:1 SHEET 1 OF 3

DRAWN T HARGRAVE-SMITH

APPROVED

DERIVED FROM

TITLE  
6 PISTON GT3 BRAKE CALIPER  
Ø390 x 36 DISC & D64 PAD

DRG NO. CP7269-1CD

**B1** INSTALLATION DRAWING

IF THIS DOCUMENT IS PRINTED IN HARDCOPY, IT IS FOR INFORMATION USE ONLY AND THEREFORE IS NOT SUBJECT TO UPDATING CONTROLS. ALWAYS REFER TO SOLIDWORKS VIEWER FOR LATEST ISSUE



THIS DRAWING IS CONFIDENTIAL AND IS SUPPLIED ON THE EXPRESS CONDITION THAT IT SHALL NOT BE LOANED OR COPIED OR DISCLOSED TO ANY OTHER PERSON OR USED FOR ANY OTHER PURPOSE WITHOUT THE WRITTEN CONSENT OF AP RACING LTD.

**AP RACING**  
 Wheler Road  
 Coventry  
 CV3 4LB  
 Tel: +44 024 7663 9595  
 Fax: +44 024 7663 9559  
 e-mail: sales@apracing.co.uk  
 Web site: HTTP://www.apracing.com

Issue No.	Alterations		
	Date & No.	Particulars	Zone
-		SEE SHEET1 FOR ISSUE INFORMATION.	

**INSTALLATION DIMENSIONS**

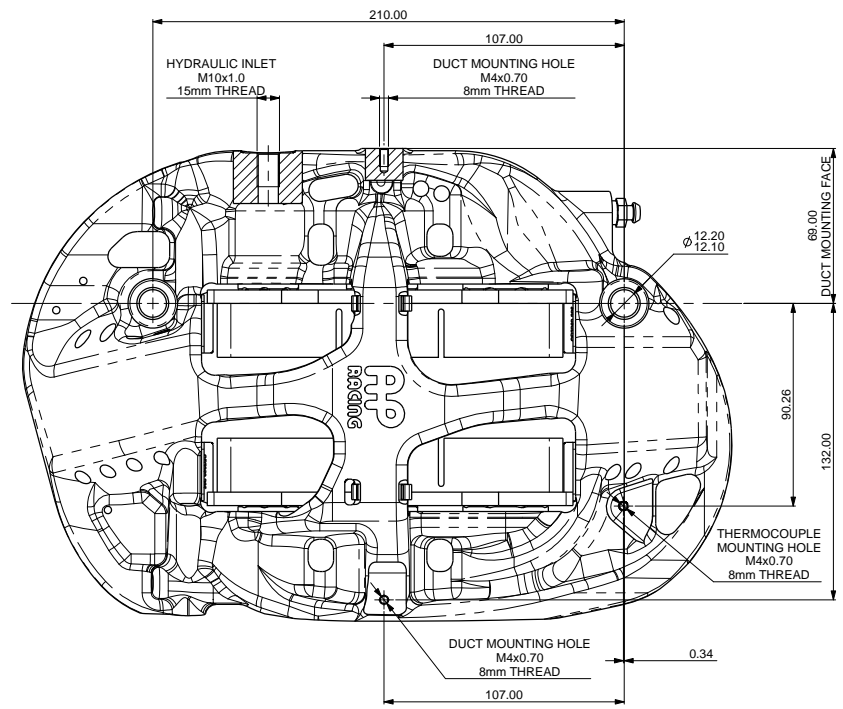
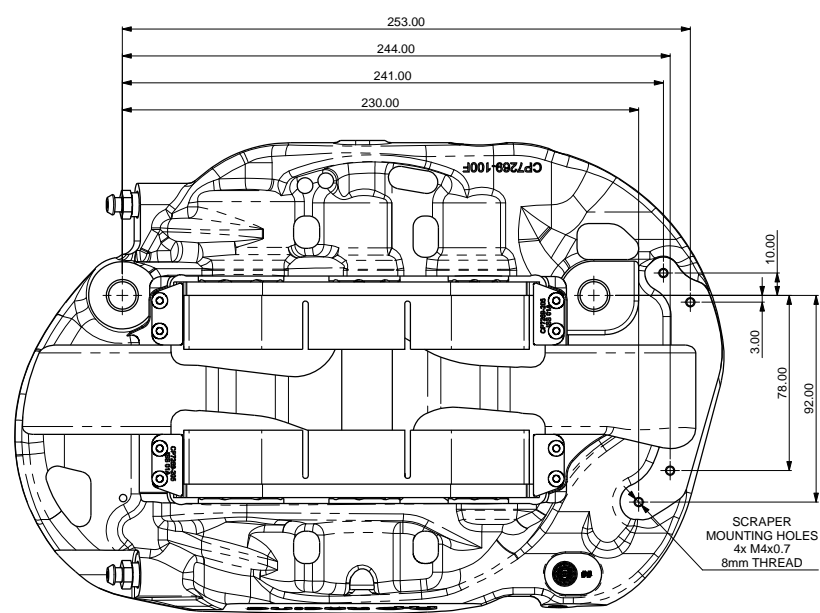
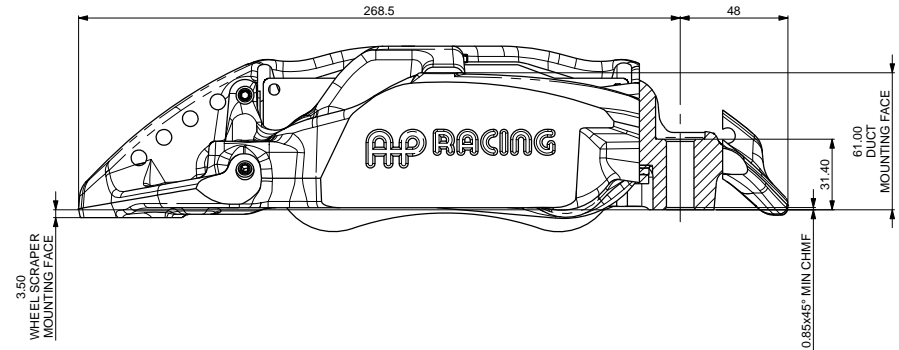
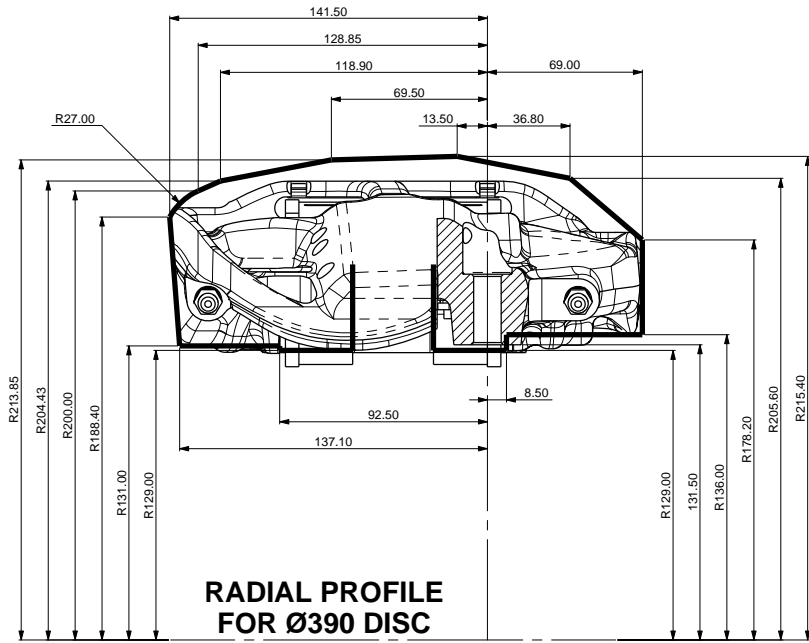

SCALE 1:1	SHEET 2 OF 3
DRAWN T HARGRAVE-SMITH	
APPROVED	
DERIVED FROM	
TITLE 6 PISTON GT3 BRAKE CALIPER Ø390 x 36 DISC & D64 PAD	
DRG NO.	CP7269-1CD

**B1** INSTALLATION DRAWING

IF THIS DOCUMENT IS PRINTED IN HARDCOPY, IT IS FOR INFORMATION USE ONLY AND THEREFORE IS NOT SUBJECT TO UPDATING CONTROLS. ALWAYS REFER TO SOLIDWORKS VIEWER FOR LATEST ISSUE



THIS DRAWING IS CONFIDENTIAL AND IS SUPPLIED ON THE EXPRESS CONDITION THAT IT SHALL NOT BE LOANED OR COPIED OR DISCLOSED TO ANY OTHER PERSON OR USED FOR ANY OTHER PURPOSE WITHOUT THE WRITTEN CONSENT OF AP RACING LTD.

**AP RACING**  
 AP Racing  
 Wheler Road  
 Coventry  
 CV3 4LB  
 Tel: +44 024 7663 9595  
 Fax: +44 024 7663 9599  
 e-mail: sales@apracings.com  
 Web site: HTTP://www.apracings.com

**SPARE PARTS AND KITS**

**CP7269-2 / 3S7L SPARES**

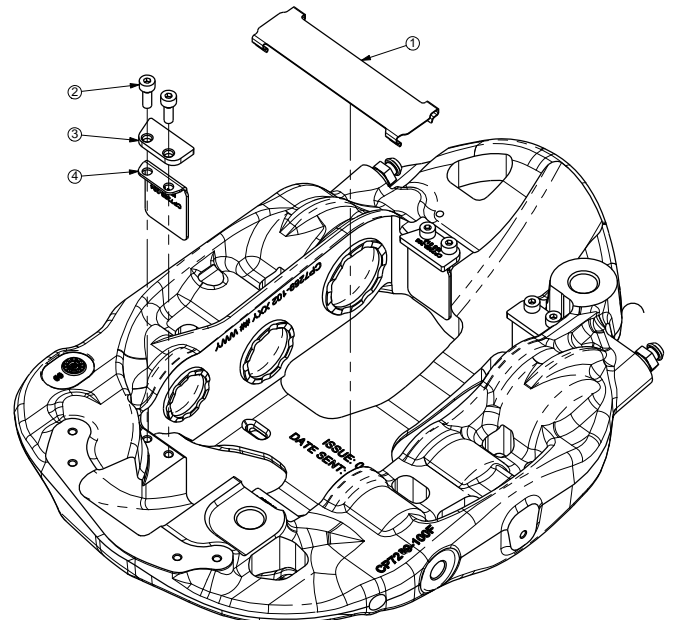

REF	DESCRIPTION	PART NUMBER	QTY PER ASSEMBLY	FITTING INSTRUCTIONS
1	BRIDGE WEAR PLATE	CP7269-203	1	
2	M4x0.7 SOCKET HEAD CAP SCREW	CP3215-115	8	APPLY A 1-2mm DROP OF LOCTITE 270 TO THE 2ND FROM LAST THREAD WHEN FITTING.
3	PAD SUPPORT	CP7269-205	4	TIGHTENING TORQUE - 4Nm ENSURE THE FLAT SIDE OF THE PAD SUPPORT LINES UP WITH THE DISC PATHWAY AS SHOWN.
4	PAD ABUTMENT PLATE	CP7269-204	4	
5	Ø27.00 [1.063"] COATED SST PISTON (C-BORE)	CP7269-200	2	
6	Ø31.75 [1.25"] COATED SST PISTON (E-BORE)	CP7269-201	2	
7	Ø38.10 [1.50"] COATED SST PISTON (J-BORE)	CP7269-202	2	
8	7lb ANTI-KNOCKBACK SPRING	CP4100-121	4	
9	7lb ANTI-KNOCKBACK SPRING	CP2667-113	2	
10	SEAL KIT (6 SEALS)	CP8518-CEJ	1	REFER TO PUBLICATION REF: P14.290 & P14.220
11	BLEED SCREW KIT	CP3880-1	2	APPLY A SMALL AMOUNT OF LOCTITE 270 TO THE THE THREADS BEFORE FITTING. TIGHTENING TORQUE - 17Nm

**OPTIONAL EXTRAS**

12	DRY BLEED VALVE	CP6300-21	2	APPLY A SMALL AMOUNT OF LOCTITE 270 TO THE VALVE THREADS BEFORE FITTING VALVE TIGHTENING TORQUE - 13Nm CAP TIGHTENING TORQUE - 4Nm
----	-----------------	-----------	---	--

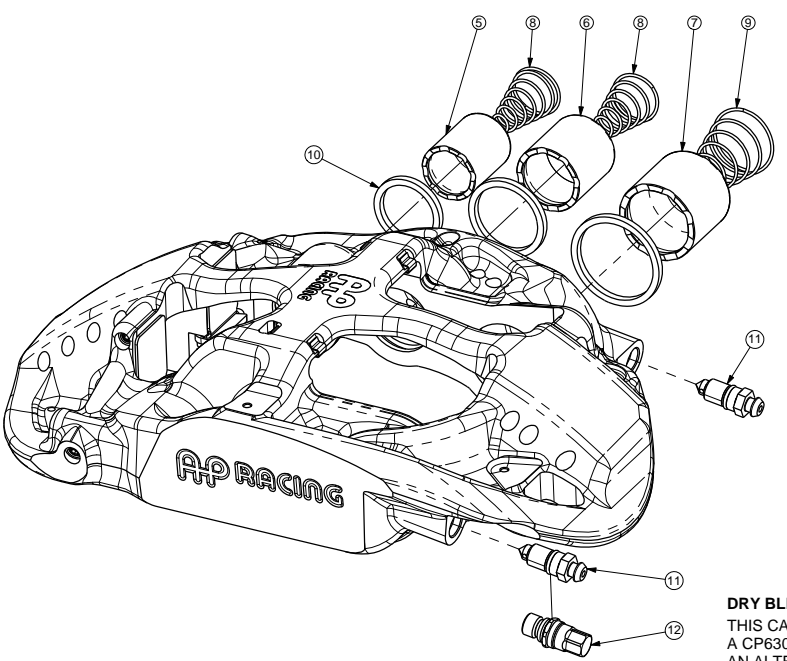

**DRY BLEED VALVE 12**  
 THIS CALIPER CAN BE FITTED WITH A CP6300-21 DRY BLEED VALVE AS AN ALTERNATIVE TO THE TRADITIONAL BLEED SCREW.

Issue No.	Alterations		
	Date & No.	Particulars	Zone
-	-	SEE SHEET1 FOR ISSUE INFORMATION.	-

SCALE 1:1 SHEET 3 OF 3  
 DRAWN T HARGRAVE-SMITH  
 APPROVED  
 DERIVED FROM  
 TITLE  
**6 PISTON GT3 BRAKE CALIPER**  
 Ø390 x 36 DISC & D64 PAD  
 DRG NO. CP7269-1CD